

CONNECTION DATA AND SCHEMATICS:

Dimensions (LxWxH):	500x850x750 mm
Cooking zones:	1
Cooking (working) surface:	340x470x H=300mm
Total/Usable capacity	30-18 liters
Electric supply:	15kW, 400V-3Nac-50/60Hz
Gas supply:	N.A.
Steam supply:	N.A.
Condensate return:	N.A.
Cold water supply:	N.A.
Hold water supply:	N.A.
Soft water supply:	N.A.
Water drain:	N.A.
Latent Heat:	10714 Watt
Sensible Heat:	1500 Watt
Net weight:	70 kg.

CONNECTION SYMBOLS

	= Electric Connection
	= Gas Connection
	= Sicotronic Connection
	= Cold Water Connection
	= Hot Water Connection
	= Soft Water Connection
	= Drain Water Connection
	= Steam Connection
	= Condensate Connection

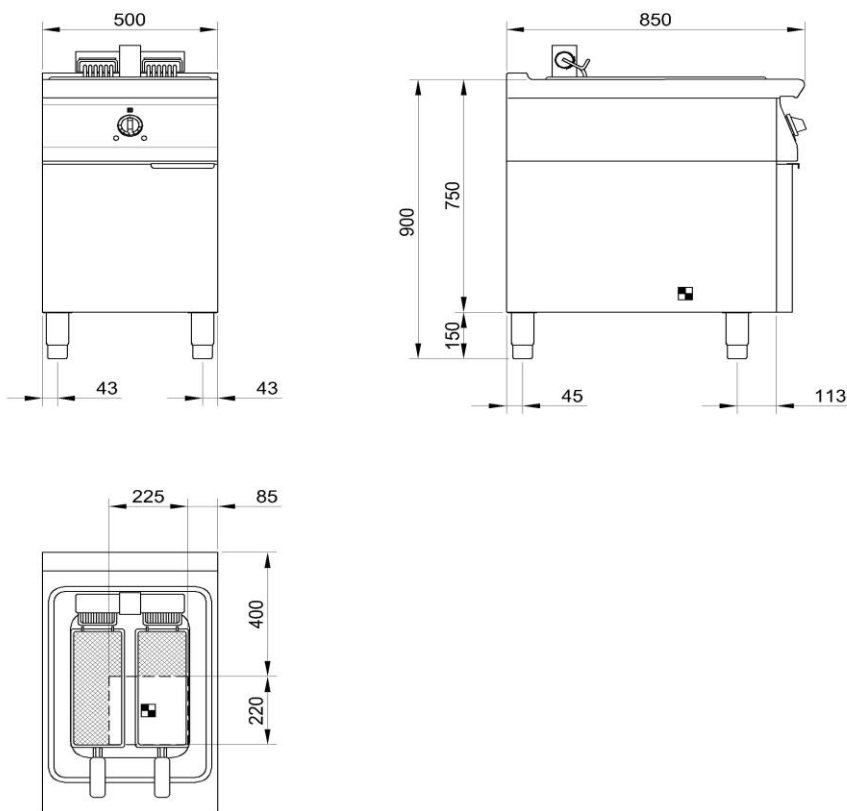

Notes:

- Connection are considered coming from the floor (SYSTEM 900-BF excluded).
- For detailed supply's connection location and in case of appliance installed in a cooking suite please refer to the order confirmation drawing for specific connection scheme.

Technische Daten und Zeichnung:

Abmessungen (LxBxH):	500x850x750 mm
Kochzonen:	1
Kochfläche (Arbeitsfläche):	340x470x H=300mm
Gesamt-/Nutzinhalt:	30-18 liters
Stromversorgung:	15kW, 400V-3Nac-50/60Hz
Gasversorgung:	N.A.
Dampfversorgung:	N.A.
Kondensatablauf:	N.A.
Kaltwasserversorgung:	N.A.
Warmwasserversorgung:	N.A.
Weichwasserversorgung:	N.A.
Wasserablauf:	N.A.
Latente Wärme:	10714 Watt
Sensible Wärme:	1500 Watt
Nettogewicht:	70 kg.

ANSCHLUSS SYMBOLE

	= Elektrischer Anschluss
	= Gasanschluss
	= Sicotronic Anschluss
	= Kaltwasseranschluss
	= Warmwasseranschluss
	= Weichwasseranschluss
	= Wasserablauf Anschluss
	= Dampfanschluss
	= Kondensatablauf

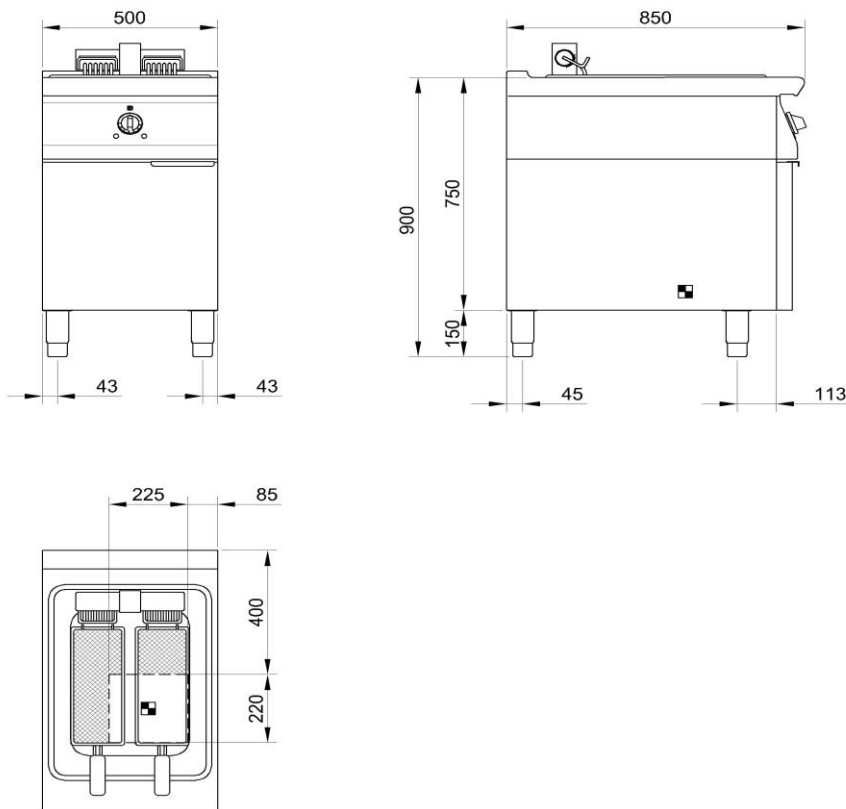
Anmerkungen:

- Die Anschlüsse sind als vom Boden kommend gezeichnet (SYSTEM 900-BF ausgeschlossen).
- Für detaillierte Angaben zu den Anschlüssen in einem Kochblock, müssen diese von Projekt zu Projekt spezifisch geplant werden.

Dati tecnici e disegno

Misure totali (LxPxH):	500x850x750 mm
Numero zone di cottura:	1
Superficie tot. cottura (lavoro):	340x470x H=300mm
Volume totale/utile di cottura:	30-18 liters
Alimentazione elettrica:	15kW, 400V-3Nac-50/60Hz
Alimentazione gas:	N.A.
Alimentazione vapore:	N.A.
Scarico condensato:	N.A.
Aliment. acqua fredda:	N.A.
Aliment. acqua calda:	N.A.
Aliment. acqua addolcita:	N.A.
Scarico acqua a perdere:	N.A.
Calore latente:	10714 Watt
Calore sensibile:	1500 Watt
Peso netto:	70 kg.

SIMBOLI DI CONNESSIONE

	= Connessione elettrica
	= Connessione gas
	= Conn. imp. ottimizzazione
	= Connessione acqua fredda
	= Connessione acqua calda
	= Connessione acqua addolcita
	= Connessione scarico acqua
	= Connessione vapore
	= Scarico Condensa

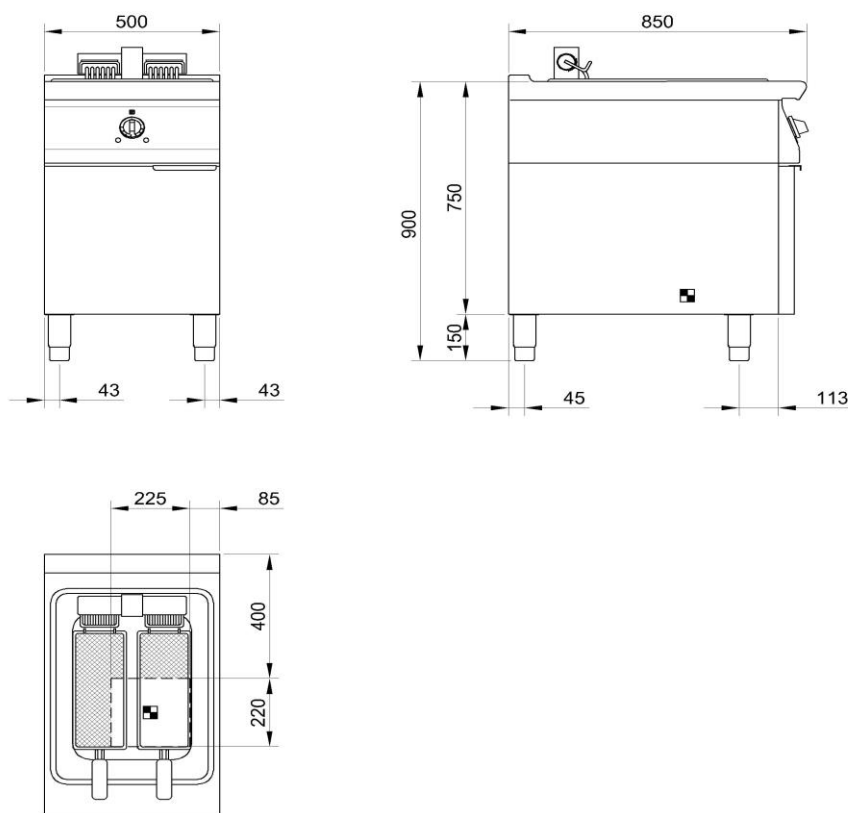
Note:

- Le connessioni sui disegni sono rappresentate provenire dal pavimento (con eccezione delle macchine con sigla "-BF").
- Per i blocchi di cottura (cucine complete) è necessario richiedere il disegno delle connessioni in fase di offerta.